

A Stand-alone Station and DSP Method for Deep Sky Objects Astrophotography

Robert Suszynski

Abstract—This article presents the basic assumptions and aspects of the design of a stand-alone station for deep sky objects (DSO) astrophotography. It describes the main elements of a project concerned with automatization, remote control and auto-guiding [1-5] of a system. The article also covers in further detail the innovative use of a driver with an ATMEGA16 microcontroller and dedicated software for controlling the astronomical dome and its synchronization with telescope movement. Furthermore, a new concept of reprogrammable digital circuit implementation for auto-guiding systems is shown, which operates with a popular CCD webcam and ST4 compatible equatorial mounts. This idea was verified by the circuit prototype implemented on an Altera Cyclone II FPGA device and tested with real sky objects. A fully functional solution for performing automatic observation is presented. The project was also designed for amateur-astronomy, and therefore, user-friendly configuration and maintenance constituted very important factors, which were taken into consideration.

Keywords—stand-alone station, remote control, convolution method, image processing, reprogrammable digital circuit

I. INTRODUCTION

WE are living in an age of dynamic development of science and technology. Among the fields which contribute most to this progress are aviation and astronautics. The human desire to lift off the ground, rising above the atmosphere, and curiosity about the mysteries of space, have both contributed to the rapid development of astronomical science. In an attempt to solve our problems here on Earth we look up into the vastness of space more and more frequently. Astronomy changes our perception of the world and broadens our knowledge of how it came into existence, what it is, and where it is going. Astronomy, apart from extending human knowledge, stimulates the development of new computational techniques and materials technology. It makes extensive use of state-of-the-art achievements in optics, electronics, computer science, precision engineering and much more.

One of the most important fields of astronomical science is observational astronomy, which takes observation of celestial objects as the most important source of information about the universe and its structure. Astronomical observations can be performed with ground-based instruments or satellites equipped with telescopes. Ground-based observations are hindered by the influence of the atmosphere, which absorbs certain radiation wavelengths which are a great source of information on space objects. Observations are carried out in two ranges of electromagnetic radiation: that visible to optical telescopes and radiation visible only to radio telescopes. The

Robert Suszynski is with Koszalin University of Technology (e-mail: roberts@tu.koszalin.pl).

rest of the spectrum is effectively suppressed by the Earth's atmosphere.

Lifting telescopes into orbit is extremely costly; hence the constant advancement of ground-based telescope technologies. Observational astronomy is growing rapidly and new discoveries are made almost every day. Moreover, it is a field of science where there is considerable cooperation between professional observers and amateurs and this cooperation enables astro-amateurs to take part in deepening our knowledge of the universe.

II. STAND-ALONE OBSERVATORY

Astronomical observations in the visible spectrum can be divided into visual and photographic. While the former undoubtedly provide magnificent views of celestial objects, they are of a lower scientific and cognitive value. Observations are now dominated by astrophotography. The availability of high-quality optical equipment, the development of electronic engineering and more refined CCD cameras together with digital methods of image processing enable us to see much more. Today, astro-amateurs obtain images of deep sky objects which were available only through large, professional telescopes just a few years ago.



Fig. 1. A stand-alone, remotely controlled station for DSO astrophotography

The high value and complexity, as well as the labor-consuming configurations of equipment, trigger a desire to build small astronomical observatories, on the one hand securing the equipment, and on the other automatizing the observations. This paper describes the structure and functioning of a stand-alone, remotely controlled optical telescope station. The system, apart from the goal of spreading

knowledge, can be used for astrophotography, photometry, new-object search and other automatic observational techniques.

Fig. 1 shows the stand-alone astronomical observatory. The casing comprises a polyester-glass dome. The opening of the observational window is located in the dome, ensuring a clear view from the horizon line to the zenith. Inside, there is a computerized astrograph as well as automatic equipment remotely controlling the telescope and dome movements.

The building of such autonomous observational stations, which can be remotely controlled, makes it possible to perform observations according to a precise plan, without the necessity of being present at the telescope. The functions fulfilled by such a station are:

- securing the equipment during periods between observations both from atmospheric conditions and access by unauthorized people (locking, heating and monitoring)
- facilitating remotely controlled, automatic observation management with the possibility of monitoring the process
- protecting the equipment from wind that might otherwise cause vibration and telescope movement
- limiting the influence of Light Pollution during observations
- ensuring the stability of equipment configuration and calibration

One of the problems which complicates the performing of astronomical observation on the ground is the constant movement of the observed objects caused by the Earth's rotation. For this reason, the telescope needs to be moving constantly, and its speed and path depend on the position of the observed object in the sky, as well as on the geographical coordinates of the place of observation. Precise tracking of the object is facilitated by an equatorial mount, where one rotational axis is parallel to the Earth's axis of rotation. Even the best mounts have mechanical imperfections and suffer adjustment errors, which cause tracking abnormalities. In order to take photographs of deep sky objects, especially with the focal length of a telescope above 200 mm, it is necessary to track the telescope during long exposures. Hence the necessity to use a second telescope coupled with a supplementary camera and a personal computer or device driver constantly calculating the telescope tracking corrections, which are sent to the mount. A telescope for DSO astrophotography is a precision optical instrument which functions in conjunction with a number of electronic, electro-mechanical and photographic devices.

Fig. 2 shows a picture of a SkyWatcher 80ED astrograph with a Canon 300D camera and Orion 80ED tracking telescope, and an Astrolumina ALccd5 camera, on an equatorial mount EQ6 PRO SynScan. The refractors are equipped with focus adjustment systems. The mount is controlled from TheSky atlas and corrected using the GuideMaster program.

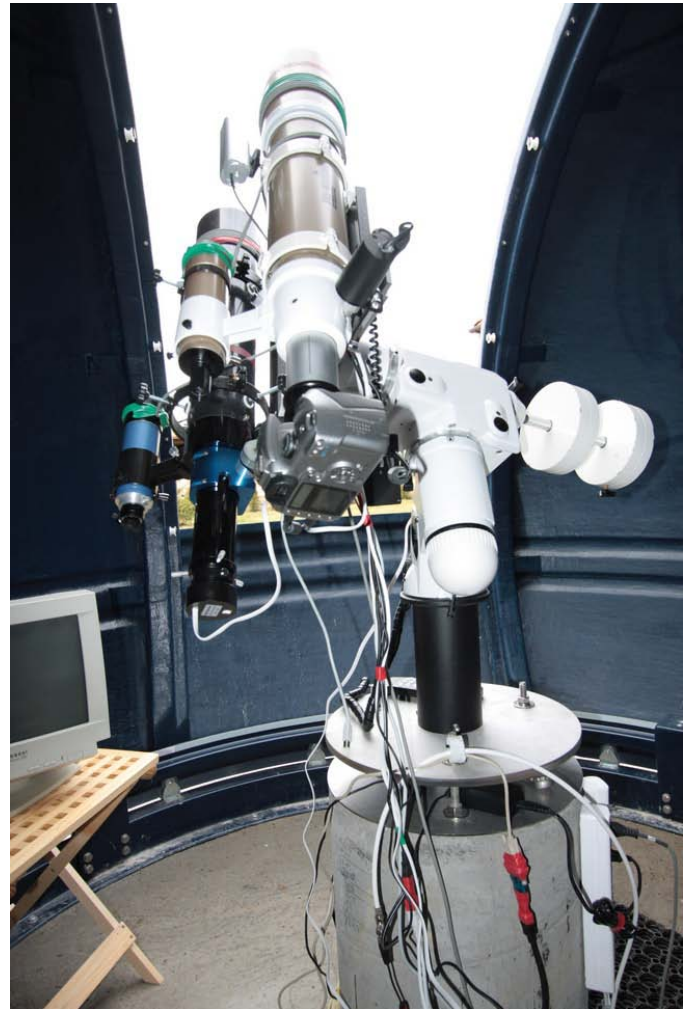

Fig. 2. Optical set used for long-exposure astrophotography

III. DOME CONTROL

During astronomical observations, the astrograph tracks an object in the sky, which makes it necessary for the dome to move in azimuth, so as to ensure visibility for the two telescopes in the observation window. Opening/closing of the flap and rotation of the dome are automatized. Two engines, an encoder and a set of sensors are controlled by the ScopeDome Card driver with an ATMEGA16 Atmel microcontroller. The most important functions of ScopeDome Card drivers are:

- controlling the power supply to the four observatory devices, turn off/turn on, telescope, CCD camera, lighting, cooling, simultaneously
- autocalibration and positioning of the dome
- controlling the engines for dome movement in azimuth and opening/closing the flap with simultaneous examination of dome and flap positions
- communication with a personal computer through USB interface
- autodiagnosics

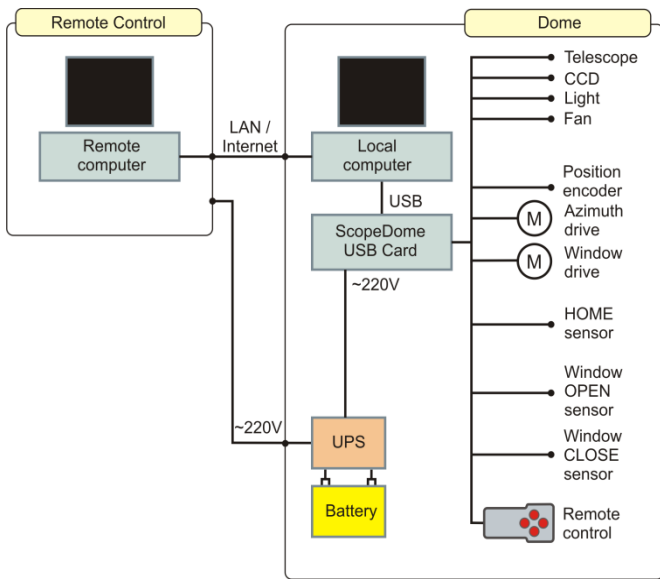

Fig. 3. Block diagram of wiring of the dome control devices and ScopeDome Card

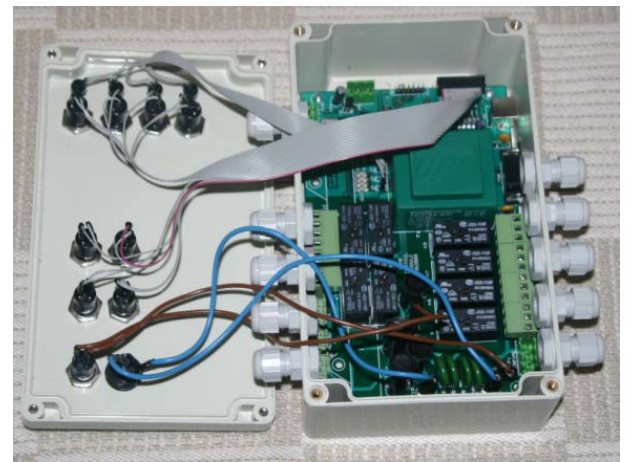

Fig. 4. The electronic elements of the driver

IV. CONTROLLING SOFTWARE

The device driver of the dome is operated by a ScopeDome Driver program, working on a personal computer, on a Windows operating system. Communication is performed through a USB interface. The software enables all the functions available to be performed through the buttons on the driver's casing. The main task of the application is to control the dome's rotation in accordance with telescope movement. The data on the telescope position are read from the telescope control program (TheSky, Stellarium etc.), compatible with ASCOM standard.

Synchronizing the dome's rotation with telescope movement requires converting the equatorial coordinates of the telescope into the horizontal coordinates of the dome. An additional complication is due to the axis of the telescope rotation not being in the geometric center of the dome and that it moves while tracking the objects. Fig. 6 shows a simplified situation, where the axis of the telescope movement is at a constant

Fig. 3 represents the wiring of the dome control devices. The driver is connected to the equatorial mount motors and to the personal computer, enabling remote control of the devices through a computer network. The ScopeDome Card system can control the dome's drive and turn on/off the connected devices by activating the appropriate buttons on the casing or can be operated through a Windows application on a personal computer. Both these ways can be used simultaneously or completely independently. Fig. 4 shows the ScopeDome Card circuits, while Fig. 5 is an electrical diagram of the microprocessor's module.

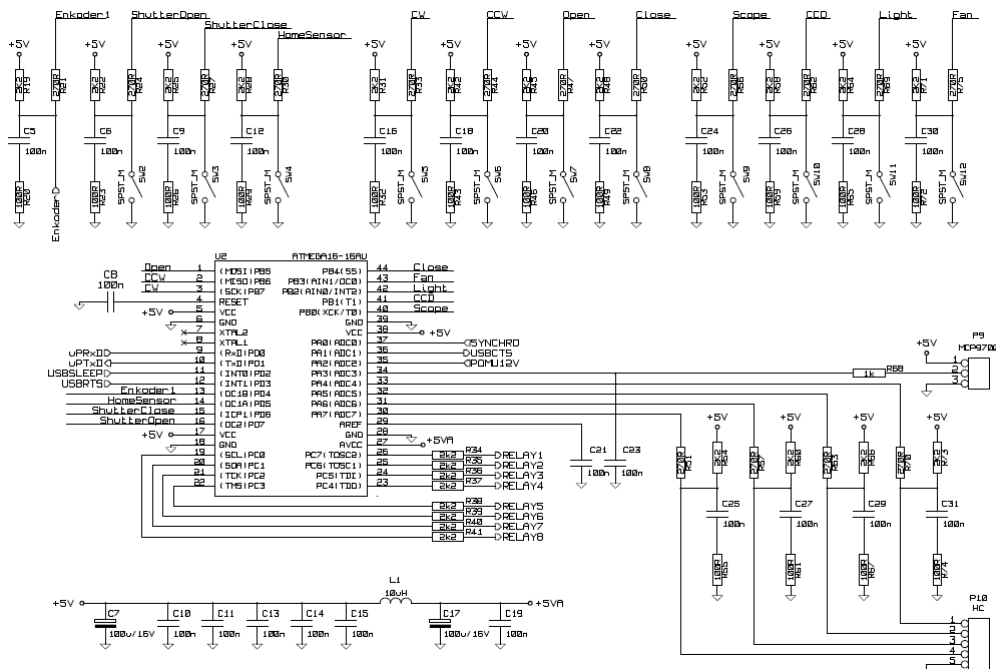

Fig. 5. Block diagram of wiring of the dome control devices and ScopeDome Card

distance r from the dome's center. The horizontal coordinates of the telescope are then calculated, and next, according to the formulas in (1), the desired azimuth of the dome is calculated. In the controlling program, there is a complex algorithm for calculating the mutual position of the dome and the telescope, which specifies the desired angle of the rotation in 15 steps, taking into consideration the geometry and measurements of the dome and the place and way of mounting the telescope.

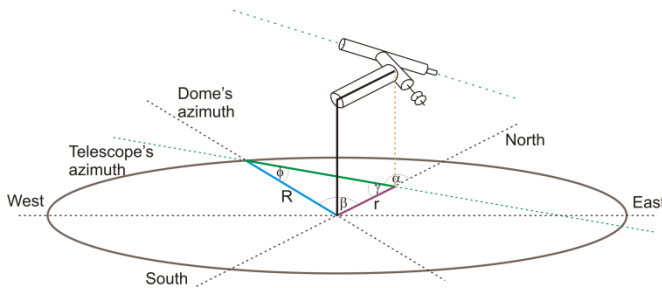

Fig. 6. Specifying the azimuth of the dome during tracking of the telescope with an equatorial mount

$$\beta = \alpha - \varphi \text{ where } \sin \varphi = \frac{r}{R} \sin \alpha \quad (1)$$

necessary dome rotation. This ensures the synchronization of telescope movement with an appropriate dome rotation, both during the search for an object and the tracking of its movement. The basic parameters of the dome are projected in sign and graphic mode. The application monitors, among other parameters, the coordinates of the telescope's target, azimuth and the movements of the dome, the state of all the sensors, and the turning off/on of all the devices (telescope, CCD, lighting, cooling). The functionality of the control program facilitates fully automatic, remote-controlled observational sessions.

Two additional programs are run on the controlling computer: one for calculating corrections in the telescope tracking, based on the image from the driving telescope, and the other for controlling the Canon 300D camera taking a series of photographs. In the lower left hand corner of Fig. 7, a screen from the monitoring camera is shown. The local computer receives two images: from inside the dome and from the camera placed on the photographing telescope, in its optical line. The constant view from the dome makes it possible to remotely control the functioning of the telescope and the dome and is, at the same time, an element of their protection.

V. AUTO-GUIDING SYSTEM

Nowadays equipment that produces remarkable, high-quality results at reasonable prices is widely available to many amateur astronomers. In order to produce images of deep sky objects, especially at focal lengths of over 200 mm, it usually becomes necessary to guide the telescope during the image exposure. Even the finest, most expensive mounts are plagued by mechanical imperfections or alignment errors, which may produce oblong stars. In Fig. 8 and 9 two pictures of the M81 Galaxy in Ursa Major are shown. The first one is made in conditions of correct star tracking by the telescope drive. The stars are circular dots with a magnitude proportional to relative brightness. However, the second one shows telescope guiding inconsistent with sky revolution. The moving of the telescope in a manner different from the speed and direction of the moving sky, causes fuzzy images of the stars proportional to drive error. The photographed object – the M81 Galaxy – is fuzzy too. Its image has lost details visible in the first picture.

Originally, guiding was done by the photographer staring through an eyepiece at a guide star and manually correcting the movement of the scope to keep the guide star's position fixed. Within the last decade, companies such as Santa Barbara Instrument Group (SBIG), have developed and sold dedicated auto-guiding systems that have unchained the photographer from his eyepiece and increased the success rate achieved. These systems are very effective, but also relatively expensive. Lastly, amateur astronomers have discovered that inexpensive, widely available webcams interacting with personal computers can be used as part of a much less expensive, but equally effective, auto-guiding system. Unfortunately, however, such systems have certain disadvantages. The place of observation must be equipped with a personal computer and an additional power supply, which is expensive and inconvenient.

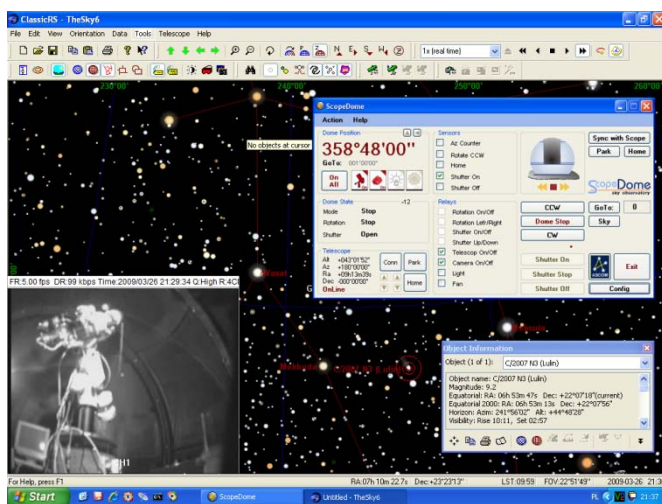

Fig. 7. A screen from the remote console of the telescope controlling computer

Fig. 7 shows an example of a computer screen during remote controlled recording of an image of the C/2007 N3 (Lulin) comet. The use of personal computer network connection, on which a ScopeDome Driver is run, and a remote console mechanism, enables the dome and the telescope to be controlled from any authorized computer in the network. The controlling of the telescope mount is performed through TheSky atlas functions. A choice of any astronomical object and its tracking with the sky rotation is available, as are other options. Simultaneously, information on the telescope's target is returned, in the ASCOM standard, used for calculating the dome's azimuth. The calculated azimuth is then sent to the ScopeDome Card driver, which performs the



Fig. 8. Picture of the M81 Galaxy taken with correct star-tracking drive consistent with sky revolution. Refractor SW 80ED, 80mm/600mm, Canon 300D, ISO 800, one exposure 300 s. Photo: Robert Suszynski.



Fig. 9. Picture of the M81 Galaxy taken with drive inconsistent with sky revolution. Refractor SW 80ED, 80mm/600mm, Canon 300D, ISO 800, one exposure 300 s. Photo: Robert Suszynski.

The main goal of the project described in this paper was to build a dedicated auto-guiding system. This should use a modified webcam to collect images of stars and a DSP system to filter and process the signals. Most of the necessary circuits can be built using CPLD devices. This approach makes it possible to build an easy to use and inexpensive auto-guiding system, which can be useful for long exposure Deep Sky Object (DSO) astrophotography.

The observation post which was used to test the auto-guiding systems is shown in Fig. 2. The upper telescope, Bresser 80mm/1000mm refractor with CCD Webcam, works as a guide star tracking system. The lower telescope, SkyWatcher 80ED 80mm/600mm refractor, interacting with the Canon 300D camera, takes the DSO pictures. Both of them are driven by the SkyWatcher EQ6 PRO mount, which drives the telescopes in both directions, under the control guiding signal on ST4 compatible input.

Modified for long exposure, the CCD Webcam, interacting with the motorized telescope driver and auto-guiding system (personal computer or dedicated circuit), can be an effective system for astronomical object tracking correction. The CCD camera takes the guide stars' pictures repeatedly. Its position is detected as co-ordinates of pixels with the greatest recorded brightness. In the case of a star drifting owing to tracking errors its image will be recorded at different positions in the next frame. Then the auto-guiding system calculates the changing of the initial position and generates correction signals for drives and moves the telescope. It should read the star image, perform data processing and calculate the correction in less than 1 second.

VI. DIGITAL METHOD FOR IMAGE CORRECTION AND STAR POSITION DETECTION

The images of stars in astrophotography are always deformed, so they are recorded by more than one pixel on the CCD matrix. The main reasons why this happens are:

- tracking errors for recorded object,
- mechanical vibration,
- optical systems defects,
- atmospheric turbulence.

Astrophotography by CCD cameras applies digital signal processing to improve the recorded images. A large number of methods modify pixel values to improve the quality of visual images or correct reordered object parameters (such as: position, relative brightness, spectral profile). Usually in these methods a new pixel value is calculated as a weighted function of the initial value of the pixel and its square surroundings.

Before changing the guide stars' position calculation, the auto-guider system makes a digital processing of the signal from the CCD camera. This reduces noise signals and improves star position calculation. Next, the new guide star position is calculated and compared with the initial position. The estimated values for star movement are used to drive correction signals' generation.

The example of the guiding process recorded by the CCD camera from the optical testing system with auto-guiding system is shown in the accompanying pictures. The reference CCD frame is taken and then improved by noise distortion and sharp filtering. Following this, it is analyzed and a small part is chosen for the next calculation. The full reference frame is shown in Fig. 10.

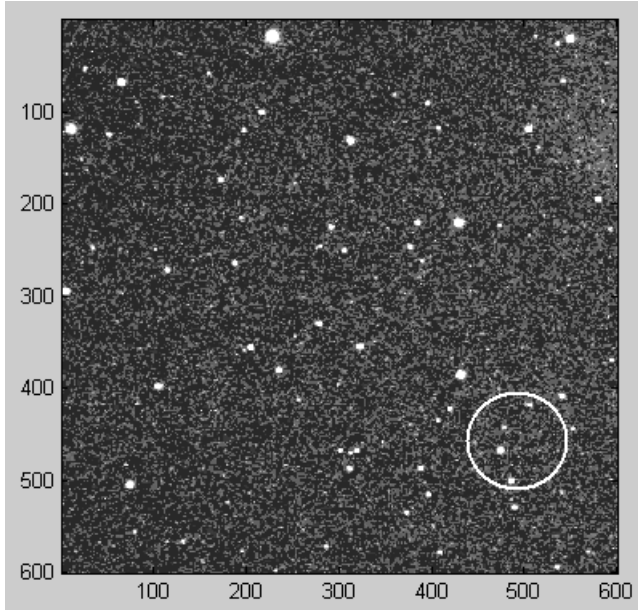

Fig. 10. The CCD frame acquired during the guiding process; four bright stars are marked and chosen for the next calculation

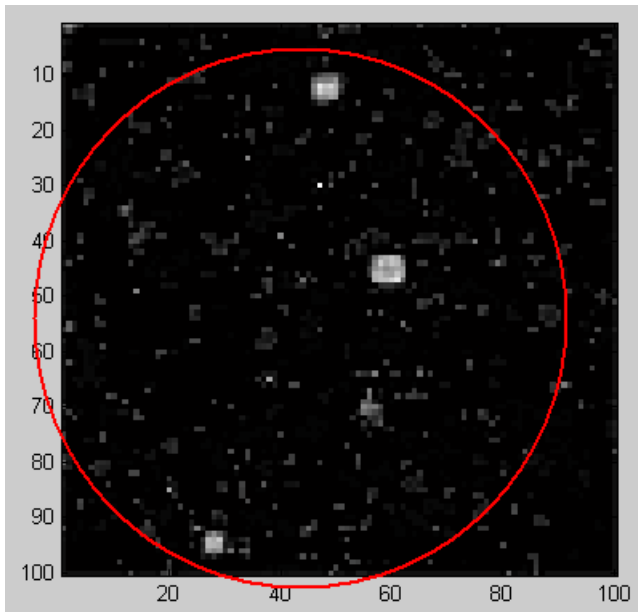

Fig. 11. Reference picture with four bright stars after noise distortion and sharp filtering; the picture is rotated for the convolution process

The circle marks four bright stars chosen for guiding. The same stars are marked in Fig. 8: the bright pixels on the left side of the M81 Galaxy.

Moving of the guide stars can be detected in the next frames from the CCD camera. Every subsequent frame is taken after one or several seconds. If the guide stars are at different positions, then the mount drives incorrectly and needs correction. The shift of guide stars is calculated from the convolution of the reference picture and the following frame. In Fig. 11 the reference picture is shown after digital filtering. In order to sharpen star outline and noise filtration, high-pass

filters are applied. Next, the picture is rotated for proper convolution process in the future.

To process the reference picture an efficient image processing algorithm was used as described in [6]. The method uses two-dimensional (2D) filtering [7] and convolution algorithm to detect movement of recording images. The following 2D transfer function matrix

$$\mathbf{H}(z_h, z_v) = [1 \quad z_h^{-1} \quad z_h^{-2}] \begin{bmatrix} -1 & -1 & -1 \\ -1 & 8 & -1 \\ -1 & -1 & -1 \end{bmatrix} \begin{bmatrix} 1 \\ z_v^{-1} \\ z_v^{-2} \end{bmatrix} \quad (2)$$

has been used for preliminary filtering. The 2D transfer function has been decomposed into two cascaded 1D transfer functions

$$\mathbf{H}(z_h, z_v) = \mathbf{H}_h(z_h) \mathbf{H}_v(z_v) \quad (3)$$

where $\mathbf{H}_h(z_h)$ and $\mathbf{H}_v(z_v)$ are horizontal and vertical vectors, respectively.

Next, 1D lossless matrices have been designed for both $\mathbf{H}_h(z_h)$ and $\mathbf{H}_v(z_v)$ [5] and cascaded to determine Rosser's matrix

$$\mathbf{R} = \begin{bmatrix} \mathbf{A} & \mathbf{B} \\ \mathbf{C} & \mathbf{D} \end{bmatrix} \quad (4)$$

where \mathbf{A} , \mathbf{B} , \mathbf{C} and \mathbf{D} denote matrices described in the Roesser's state space model of 2D linear system defined by the equations

$$\begin{cases} \begin{bmatrix} x^h(i+1, j) \\ x^v(i, j+1) \end{bmatrix} = \mathbf{A} \begin{bmatrix} x^h(i, j) \\ x^v(i, j) \end{bmatrix} + \mathbf{B}u(i, j) \\ y(i, j) = \mathbf{C} \begin{bmatrix} x^h(i, j) \\ x^v(i, j) \end{bmatrix} + \mathbf{D}u(i, j) \end{cases} \quad (5)$$

where i and j are integer-valued vertical and horizontal coordinates, respectively,

$x^h(i, j) \in R^h$ and $x^v(i, j) \in R^v$ are the horizontal and the vertical state vectors, respectively,

$u(i, j) \in R^m$ and $y(i, j) \in R^l$ are the input and the output vector, respectively,

\mathbf{A} , \mathbf{B} , \mathbf{C} , \mathbf{D} are real constant matrices of $r \times r$, $r \times l$, $k \times r$ and $k \times l$ dimensions, respectively.

Finally, the Roesser's matrix has been rearranged [4] to the following form

$$\mathbf{R} = \prod_{i=1}^l R_{s_1, t_1}(\phi_i) E \prod_{j=1}^l R_{u_j, w_j}(\varphi_j) \quad (6)$$

where

$$E = \begin{bmatrix} \pm 1 & 0 & \dots & 0 \\ 0 & \pm 1 & \dots & 0 \\ \dots & \dots & \dots & \dots \\ 0 & 0 & \dots & \pm 1 \end{bmatrix}$$

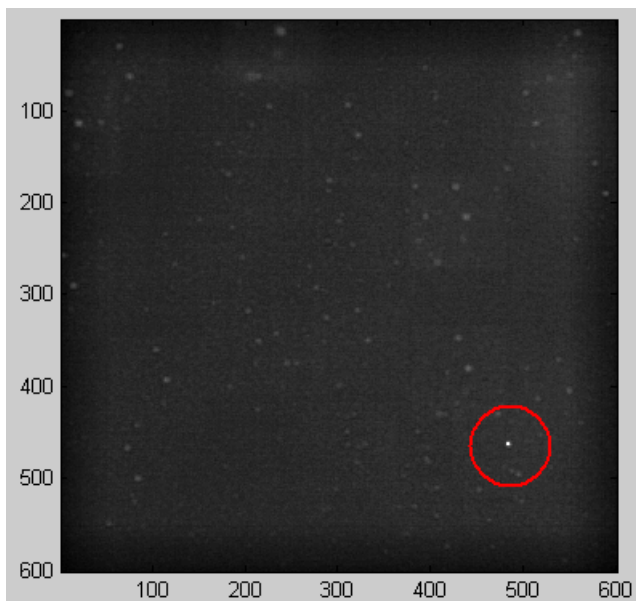

Fig. 13. Result of the convolution of the CCD frame and reference picture; the bright point is the position of the guiding stars

The convolution process accuracy is presented in Fig. 14. The spike in the picture represents the highest value of the convolution matrix corresponding to the guide stars' new position. The distance between this value and the rest of the signals is so high that we can determine shift with considerable reliability.

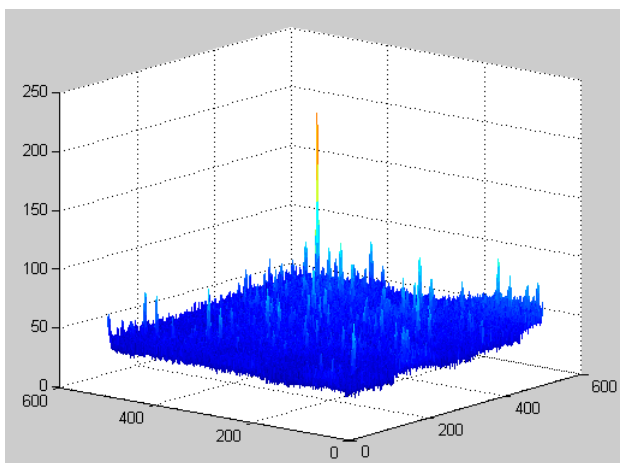

Fig. 14. Result from the convolution of the CCD frame and the reference picture; the maximal value is at the guiding stars' co-ordinates

VII. CONCLUSION

In this paper the circumstances and main guidelines for building an easy-to-use and inexpensive auto-guiding system which can be useful for long exposure Deep Sky Object astrophotography have been presented. The design and implementation at Altera Cyclone II FPGA devices was performed. The example of digital signal processing block is shown. The calculation for real data of astronomical object from CCD camera at FPGA testing board were carried out.

Proposed methods gave the correct results. Images acquisition and digital processing speed of test board were sufficient for correct equatorial mount guiding. The proposed FPGA prototype can be used for auto-guiding system in long exposure astrophotography.

The stand-alone station for astrophotography of deep space objects is fully functional and ready to perform automatic astronomical observations. One of the innovative solutions applied in the project is a system of synchronizing dome rotation with telescope movement. The system acquires information from the telescope on its coordinates, consistent with ASCOM standard, calculates them, taking into consideration the mutual geometry of the dome and the telescope, and transfers the data to the microprocessor executive driver, which controls the dome's drive.

A series of equipment tests and successful astrophotography sessions proved the usefulness of the solutions proposed. The use of microprocessor technology for automatization of observations, and the possibility to perform them remotely, significantly influences the quality of the obtained results. The results achieved so far, can form the basis for further research and for expanding the station. Examples of deep sky object pictures made with the use of the solution presented in the article can be found at the following website: www.astronomia.koszalin.pl.

REFERENCES

- [1] P.F. Li, J.X. Huang, W.X. Xie, L.Q. Li, "Intelligent Tracking Algorithm using Fuzzy-based Adaptive ALPHA_BETA Filter for Maneuvering Target," in *Proc. 9th International Conference on Signal Processing*, vol. 1, Beijing, China, 2008, pp. 337-340.
- [2] L.P. Wang, S.H. Hu, X.Y. Zhang, "Detecting and Tracking of Small Target Under the Background of Sea Level," in *Proc. 9th International Conference on Signal Processing*, vol. 2, Beijing, China, 2008, 989-992.
- [3] R. Suszynski, "Digital processing of CCD images for auto-guiding astrophotography system," in *Proc. 15th IEEE International Conference Mixed Design of Integrated Circuits and Systems*, Poznan, Poland, 2008.
- [4] B. Piatek, "Autoguiding on the Macintosh," in *Proc. Macintosh Astronomy Workshop I*, Illinois Institute of Technology, September 8, 2005.
- [5] D. Ratledge, "Digital Astrophotography: The State of the Art," in *Patrick Moore's Practical Astronomy Series*, Springer-Verlag London Limited, 2005.
- [6] R. Suszynski, K. Wawryn, R. Wirski, "2D image processing for auto-guiding system," in *Proc. IEEE 54th International Midwest Symposium on Circuits and Systems (MWSCAS)*, Seoul, 2011.
- [7] K. Wawryn, R. Wirski, and Bogdan Strzeszewski, "Implementation of Finite Impulse Response Systems Using Rotation Structures," in *Proc. International Symposium on Information Theory and its Applications (ISITA2010)*, Taichung - Taiwan, 2010.
- [8] R. Wirski, "Synthesis of orthogonal Roesser model for two-dimensional FIR filters," in *Proc. International Symposium on Information Theory and its Applications (ISITA2010)*, Taichung - Taiwan, 2010.
- [9] H. Lee, G.E. Sobelman, "Performance evaluation and optimal design for FPGA-based digit-serial DSP functions," *Computers and Electrical Engineering*, vol. 29, no. 2, March 2003, pp. 357-377.
- [10] S. Brown, J. Rose, "FPGA and CPLD architectures: A tutorial," *IEEE Design & Test of Computers*, vol. 13, no. 2, Summer 1996, pp. 42-57.
- [11] K. Bondalapati, V.K. Prasanna, "Reconfigurable computing systems," in *Proc. of the IEEE*, vol. 90, no. 7, July 2002, pp. 1201- 1217.